

DESCRIPTION

The SLT-S Splice Kit is for use with all versions of Nelson Heat Tracing Systems' SLT & CLT heater cables.

KIT CONTENTS

- 5 Shrink Tubes, 12mm (0.5") diameter, 152mm (6") length
- 5 Shrink Tubes, 25mm (1.1") diameter, 229mm (9") length
- 5 Uninsulated Splice Connectors
- 10 Insulated Splice Connectors

OVERJACKET STRIPPING PROCEDURES

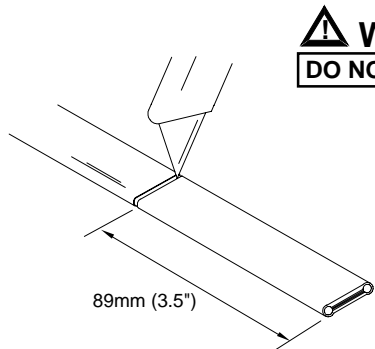

WARNING:
DO NOT CUT BRAID

- 1 Lightly cut around heater overjacket 89mm (3.5") from the end. Bend cable to break the overjacket.
- 2 Lightly cut overjacket up the center between first cut mark and the cable end. Bend cable to break

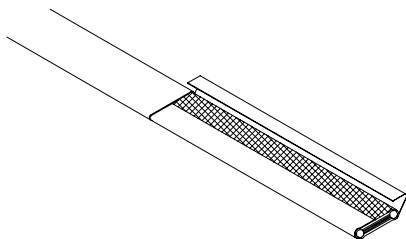

- 3 Remove overjacket from heater cable.

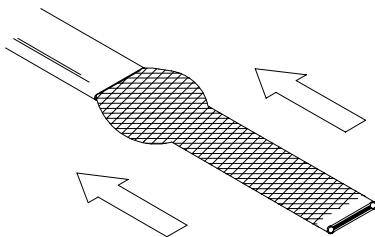

- 4 Move braid back toward the overhacket, creating a bulge.

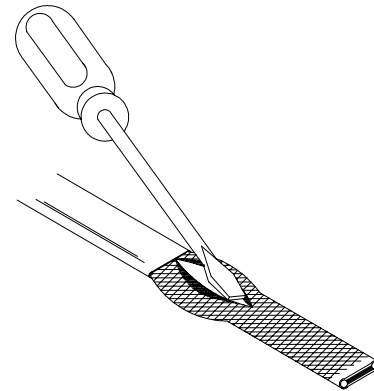

- 5 At the bulge, separate the braid to make an opening.

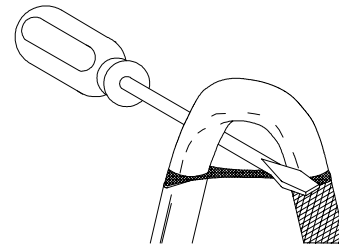

- 6 While bending the heater cable, work it through the braid opening.

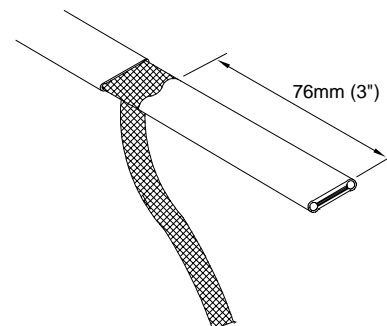

- 7 Pull braid tight.
- 8 Repeat steps 1 - 7 for both heater cables.
- 9 Proceed to "Outer Jacket Stripping Procedures", sheet 2.

OUTER JACKET STRIPPING PROCEDURES

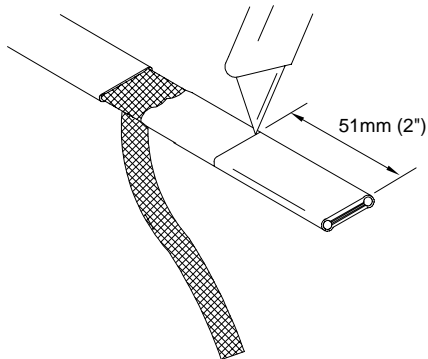

1 Lightly cut around heater outer jacket 51mm (2") from the end. Bend cable to break outer jacket.

2 Lightly cut the outer jacket up the center between the first cut mark & the cable end. Bend cable to break outer jacket.

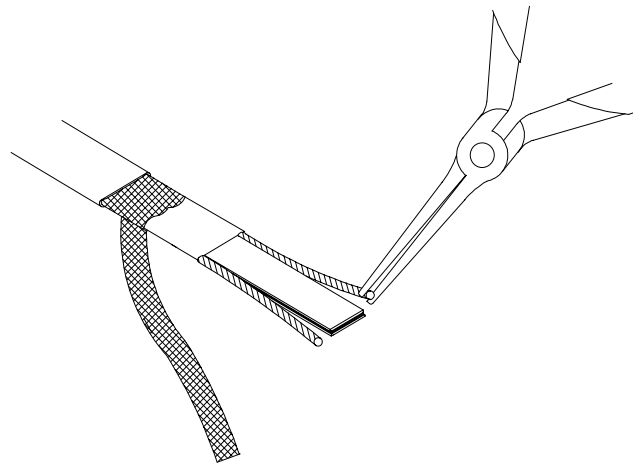

5 Starting at the end, pull each bus wire away from the core material.

6 Remove exposed core material.

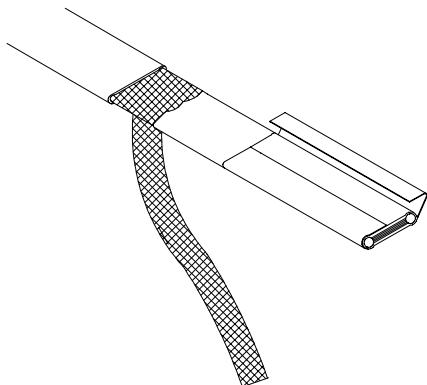

3 Remove jacket from the heater cable.

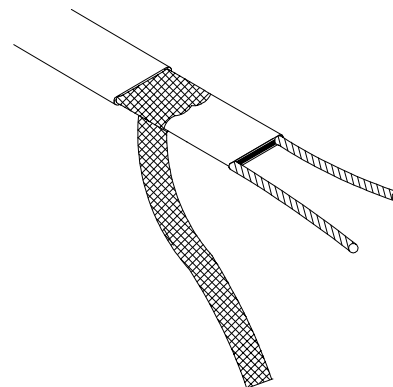

7 Repeat steps 1 - 6 for both heater cables.

8 Proceed to "Shrink Tube Procedures", sheet 3

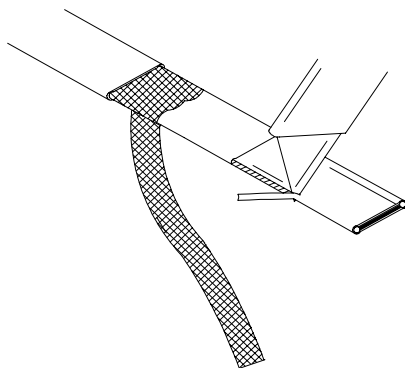

4 Shave core material from the outside of each bus wire.

⚠ WARNING:
DO NOT CUT BUS WIRES

SHRINK TUBE PROCEDURES

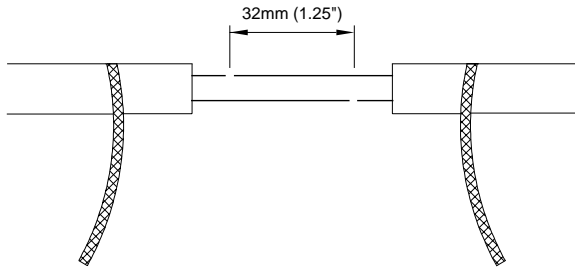

- 1 Position both heater cables with the ground braid on the same side. Remove 32mm (1.25") of bus wire from each heater cable to offset for insulated splice connectors.

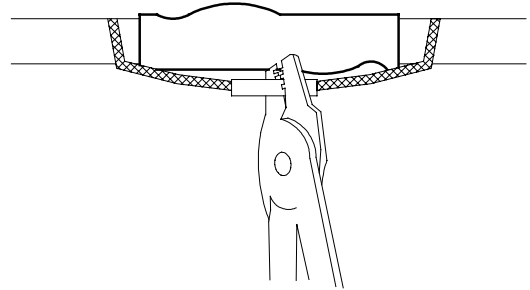

- 5 If necessary, cut excess length from braid straps. Crimp the braid straps together into an uninsulated splice connector, then secure the connector at the indented area with one and a half wraps of electricians' tape.

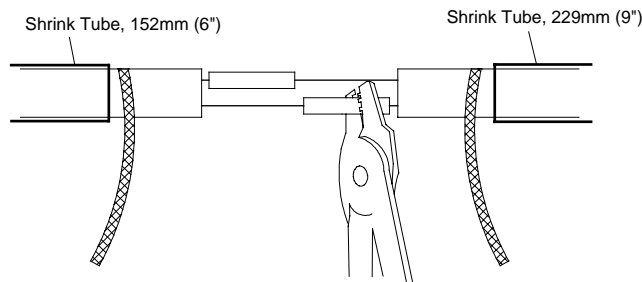

- 2 Slide one 152mm (6") length shrink tube over one of the heater cables and one 229mm (9") shrink tube over the other heater cable.
- 3 Crimp an insulated splice connector to each bus wire connecting the two heater cables together.

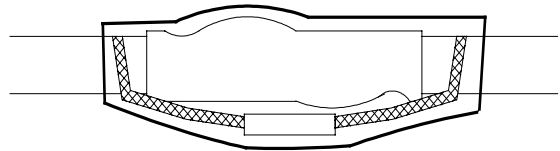

- 6 Center the 229mm (9") shrink tube over the splice and braid connection. Shrink with heat gun until completely shrunk. A uniform bead of glue should appear around the ends of the shrink tube.

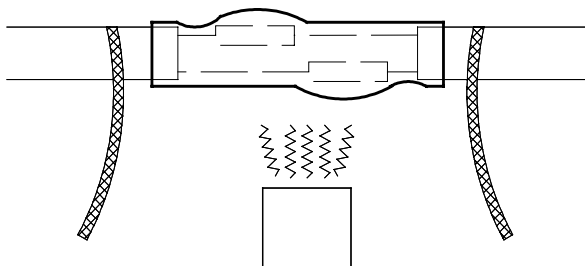

- 4 Center the 152mm (6") length shrink tube over the connectors leaving the braid straps exposed. Shrink with heat gun until completely shrunk. A uniform bead of glue should appear around the ends of the shrink tube.