



*We manage heat®*

# **SC™-40 Satellite Contactor**

## **Installation and Operation Manual**

### **ENVIRONMENTAL TECHNOLOGY, INC.**

1302 High Street  
South Bend, Indiana 46601  
(219) 233-1202 or (800) 234-4239  
FAX (219) 233-2152 or (888) 234-4238  
[www.networketi.com](http://www.networketi.com)

Copyright © 1995, 2000 Environmental Technology, Inc.

## **DISCLAIMER**

Environmental Technology, Inc. makes no representations or warranties, either expressed or implied, with respect to the contents of this publication or the products that it describes, and specifically disclaims any implied warranties of merchantability or fitness for any particular purpose. Environmental Technology, Inc. reserves the right to revise this publication and to make changes and improvements to the products described in this publication without the obligation of Environmental Technology, Inc. to notify any person or organization of such revisions, changes or improvements.

The ETI logo, Snow Switch, Floorstat, Tracon, We Provide Managed Heat, We Manage Heat are registered trademarks of Environmental Technology, Inc.  
99+, ADH, APS, ARC Fault, CIT, DC Trace, Digital Anticipation, EDH, EUR, ES, FMC, FWT, GIT GPT, HSC, LCD, RCD, RCU, RMC, SIT and Snozone are Environmental Technology, Inc. trade  
Marks.  
Copyright © 2000 Environmental Technology, Inc. All rights reserved.

All rights reserved. No part of this manual may be reproduced or translated in any form or by any means, electronic or mechanical including photocopying and recording, for any purpose without the express written consent of Environmental Technology, Inc.

# Installation

---

Install in accordance with the requirements of all applicable electrical and building codes and regulations.

---

## Enclosure

The SC-40 nonmetallic enclosure is suitable for installation in environments corresponding to NEMA 1, 2, 3R, 12 and 13 applications. The SC-40 was designed to operate satisfactorily over an ambient temperature range of -40° to 140° F. (-40° to 60° C.).

Using the integral external mounting flanges, the SC-40 is intended to be installed on fixed, vertical, flat surfaces as it was shipped; no disassembly or component removal is required. The choice of anchors and companion mounting hardware should be appropriate for both the mounting surface and the environment. The mounting flanges accommodate a range of fastener diameters up to ¼" (6.35 mm).

## Conduit

The SC-40 nonmetallic enclosure is furnished with three conduit entries; single-phase models with (3) 1-3/64" (27 mm) dia. holes, and three-phase models with (1) 1-3/64" (27 mm) dia. hole on top, and (2) 1-11/16" (42.85 mm) dia. holes on the bottom. The conduit entries are to be utilized in the following manner:

- Bottom, right: Line voltage (208, 240, 277, or 480 V. ac) supply branch circuit conductors.
- Bottom, left: Snow/ice melting system load branch circuit conductors.
- Top, right: Low voltage (Class 2) wiring linking the SC-40 with the master APS™-4. Also may be used as a junction to network additional Satellite Contactors.

Prior to finalizing the arrangement and selection of raceways, familiarize yourself with the specific requirements of both the grounding and wiring sections of these instructions. If the SC-40 is to be installed in a hostile environment, ensure that all conduit terminations are watertight.

## Grounding

Effective grounding is key to the safe, proper operation of the SC-40. Based on the planned installation, you may elect one (or both) of the following means to accomplish this.

- Provide a continuous copper equipment grounding conductor routed with the branch circuit conductors.
- *Caution:* If the branch circuit conductors are contained within continuous rigid metallic raceway(s), connect a copper bonding jumper to each line voltage race way terminating at the nonmetallic enclosure using a grounding type bushing or conduit hub or locknut having approved grounding provisions.

The equipment grounding conductor(s) and/or the bonding jumper(s) are, each, to be properly sized for the rating of the branch circuit overcurrent protective device employed and shall be terminated in the mechanical lug designated "G" *without* passing through the ground fault detection/interruption system toroidal (donut) current transformer.

## Wiring - Line Voltage

Line voltage (208, 240, 277, or 480 V. ac) supply and load branch circuit conductors must be copper and must have sufficient ampacity to limit the maximum insulation temperature to 60° C. To assist in your selection of a minimum wire size appropriate for the snow/ice melting system load, see Table 1. (*Caution:* For circuits of extraordinary installed length, it may be necessary to utilize larger conductors to minimize voltage drop.)

All line voltage supply conductors *must* be passed through the donut current transformer enroute to being connected at the contactor line side terminals. (Snow/ice melting system load conductors should *never* be passed through the donut.) Supply and load conductors are secured at the contactor compression terminals, torqued to 40 lb.-in. Figure 1 shows supply and load connections for line voltages of single and three phase SC-40 units.

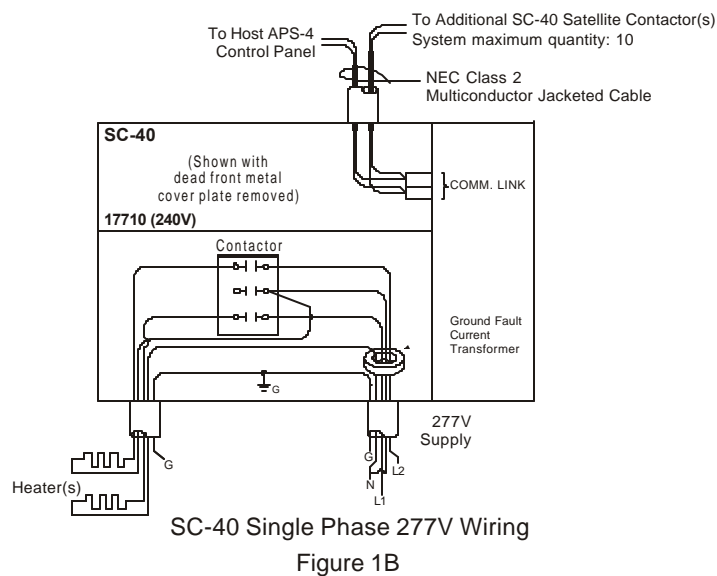
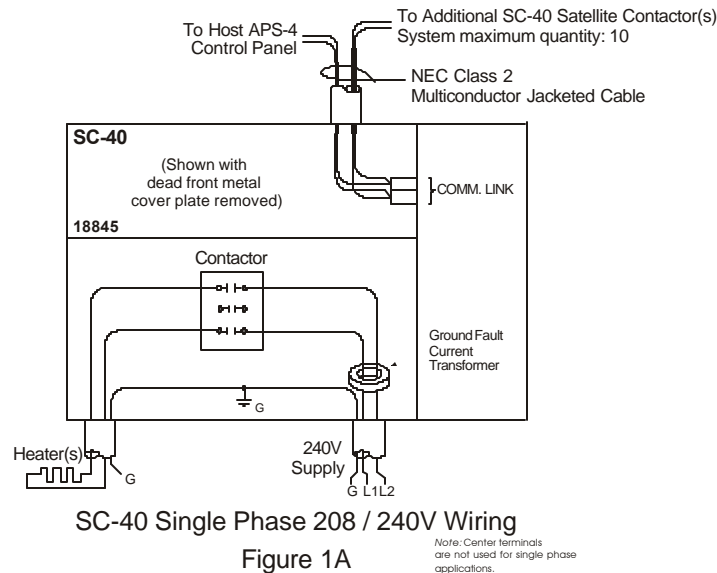

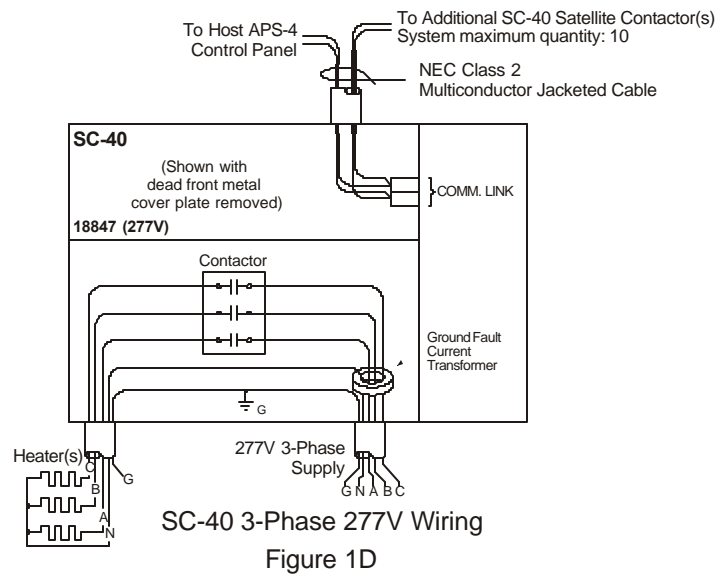
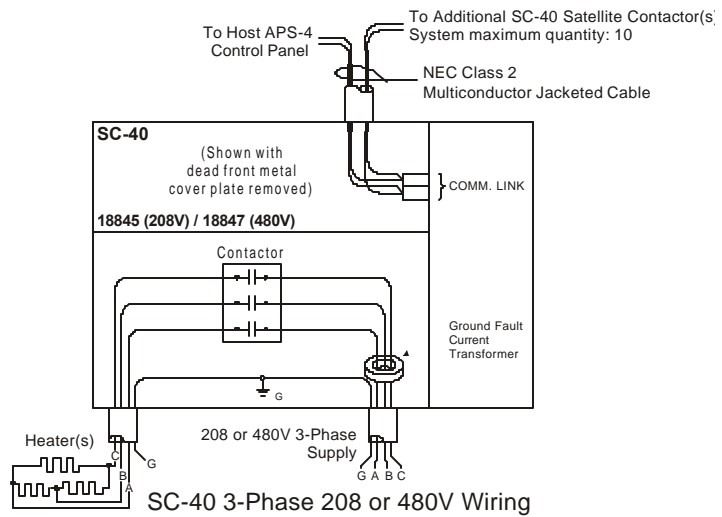

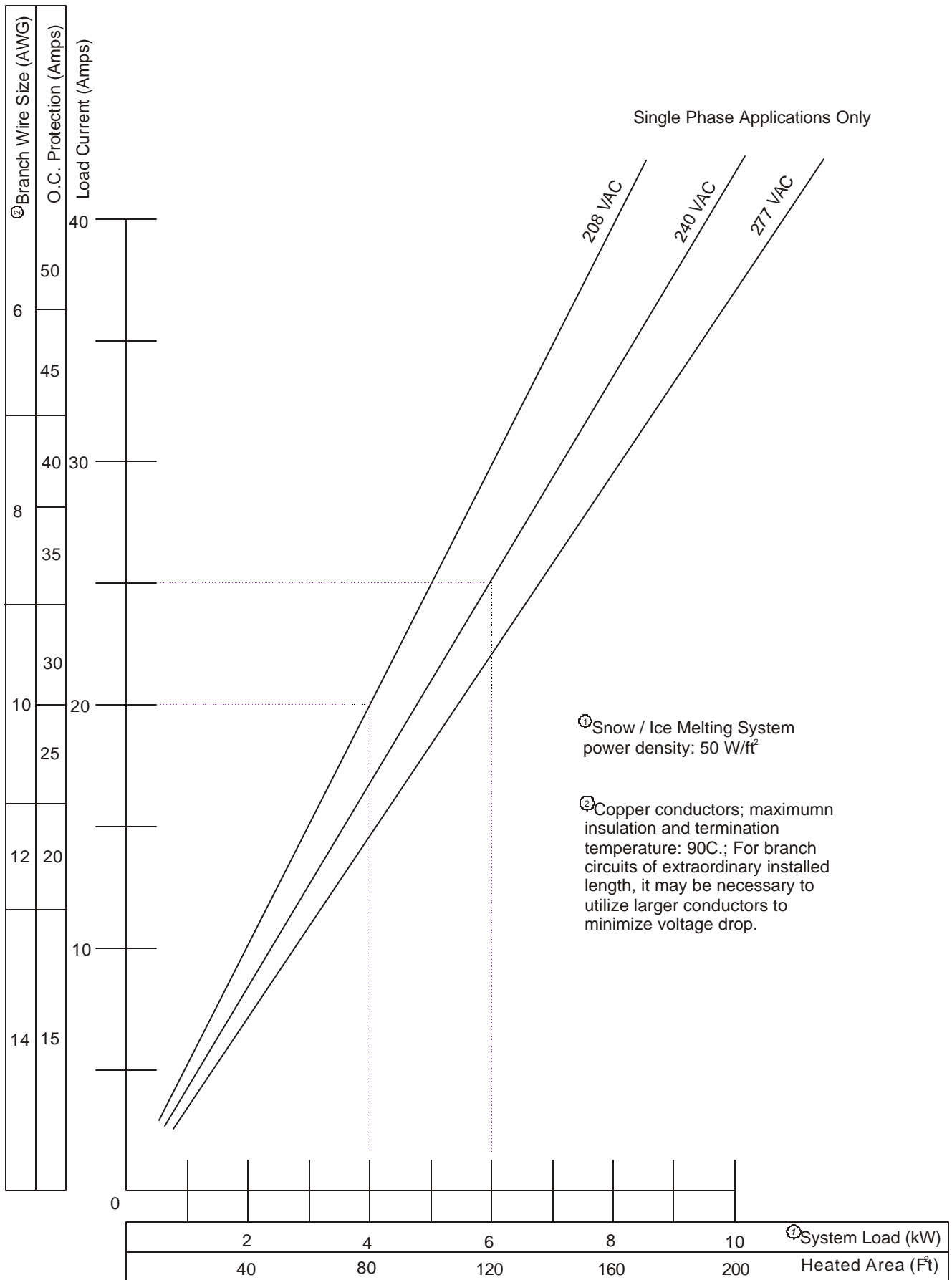

Table 1  
Snow / Ice Melting System

## Wiring - Class 2 Low Voltage

The low voltage terminal block is shown in Figure 2, below.

The Class 2 circuit may have an equivalent installed length of 2,000' (609.6 meters) utilizing 2-conductor #18 AWG - jacketed cable up to 500 feet (153 meters). For distances greater than 500 feet(153meters), utilize #12 AWG - jacketed cable. For best results, run all sensor and remote cables through an independent conduit. Contact ETI application's personnel if you have any questions or need for assistance.

The two conductors may be connected to the CommLink terminals at your discretion and without maintaining a uniform convention at each subsequent SC-40 that may be included in the system.

Upon completing all line and low voltage and grounding terminations, and prior to energizing the SC-40, reinstall the dead front metal compartment cover.

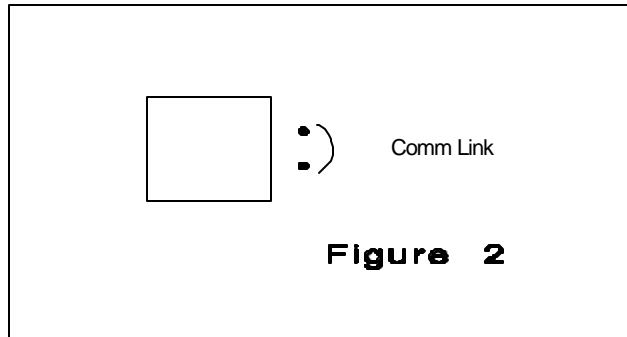

## Checkout and Operation

Thoroughly check the system before placing it in service. Our experience shows that installation errors cause the majority of problems. Frequently encountered problems include wiring errors. Simple electrical tests and visual inspections identify these problems.

Once the SC-40 installation has been properly completed, it may be energized. (Note: If the snow/ice melting system is comprised of more than one SC-40 Satellite Contactor, energization will entail the closing of multiple branch circuit overcurrent protective devices.) The green "Supply" LED will be illuminated on each successive unit as its respective supply circuit is energized.

Once weather tracking has begun, should any installed sensor detect snow/ice, the amber "Heater" LED on all installed SC-40 Satellite Contactors having an energized power supply will be illuminated as each initiates its respective snow/ice melting system load.

Independent of meteorologic conditions, the functional operation of the installed snow/ice melting system may be manually verified by momentarily depressing the "Heater Test" push button. Upon releasing, the contactor will close, energizing the heaters for a 1-minute interval as signaled by the amber "Heater" LED. This procedure may be repeated, if desired, and the SC-40 will return to automatic sensing state at the conclusion of each test. To verify ground fault detection/interruption operation, momentarily place the "Ground Fault" spring-return toggle in the "Test" (down) position and observe that the red "Ground Fault" LED will continuously flash; restore this system by momentarily placing the spring-return toggle in the "Reset" (up) position. It is suggested the SC-40 be, annually, subjected to this functional test.

Should a ground fault occur, the snow/ice melting system is automatically deenergized and the red "Ground Fault" LED will continuously flash. If this state persists following an attempt to reset in the manner previously described, a ground fault exists and troubleshooting/servicing is required. The ground leakage current threshold factory setting is 30 ma.

## QUESTIONS AND COMMENTS

*For technical help, questions or comments concerning this product or any of Environmental Technology, Inc. products contact the Customer Service Department between 8:00am and 5:00pm EST (UTC minus five hours) at*

*Voice: 800.234.4239 (USA and Canada)  
219.233.1202 (elsewhere)*

*Fax: 888.234.4238 (USA and Canada)  
219.233.2152 (elsewhere)*

*E-mail: [helpdesk@networketi.com](mailto:helpdesk@networketi.com)*



**ENVIRONMENTAL TECHNOLOGY, INC.**

1302 High Steet, South Bend, IN 46601

The ETI logo, Snow Switch, Floorstat, Tracon, We Provide Managed Heat, We Manage Heat are registered trademarks of Environmental Technology, Inc.  
99+, ADH, APS, CIT, Digital Anticipation, EDH, EUR, ES, FMC, FWT, GIT GPT, HSC, LCD, RCD, RCU, RMC and SIT are Environmental Technology, Inc. trade marks.  
Copyright © 2000 Environmental Technology, Inc. All rights reserved.